



Part Number 1006

2004-10 * Ford F-150 5.4L

2005-10 * F-250, F-350 5.4L

2005-10 * Ford Expedition 5.4L

2006-08 Lincoln Mark LT 5.4L

*2010 model year is not CARB legal

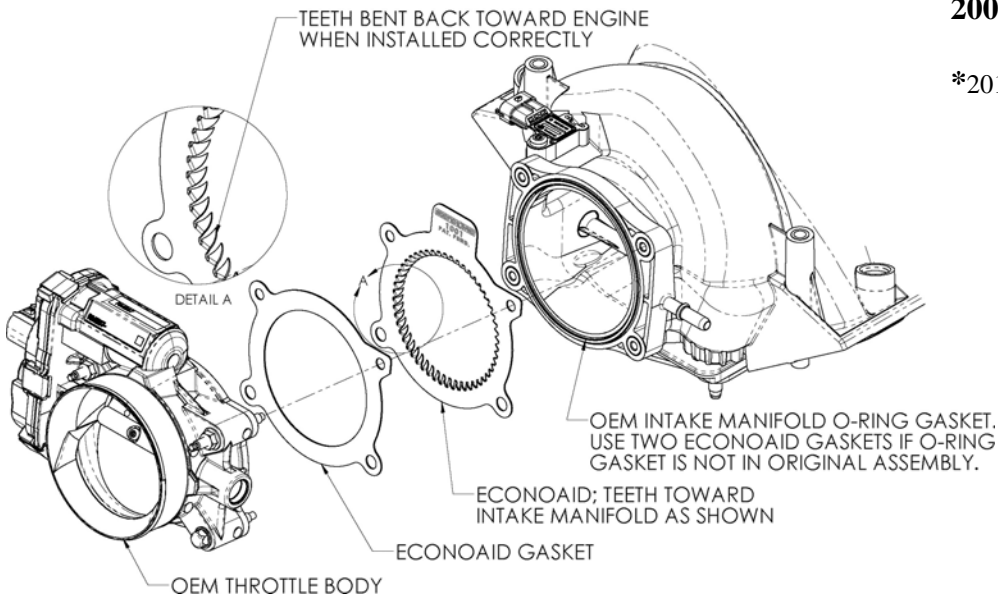

Tools Required For Installation

5/16", 10mm Socket

Ratchet and Extension

Parts List

#1	ECONOAID	x1
#2	Gasket	x1

Thank you for purchasing the ECONOAID Throttlebody Booster. Please read the instruction manual carefully before proceeding with the installation. Contact ECONOAID @ (888) 876-4676 8:00 AM - 5:00 PM MST Weekdays for questions regarding fit or instructions that are not clear to you. Your ECONOAID Throttlebody Booster was carefully inspected and packaged. Check that no parts are missing, or were damaged during shipping. If any parts are missing, please contact ECONOAID.

U.S. Pat. #7,665,442

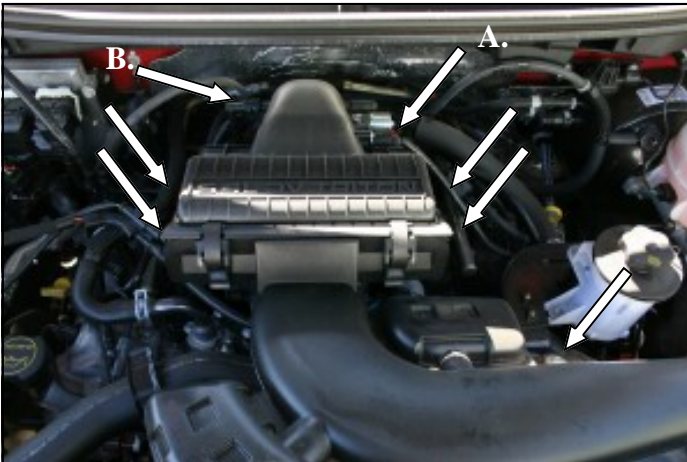

1. **Disconnect the negative battery cable!**

A.) Slide the red tab, and squeeze the black tab on the mass air sensor connector, and disconnect it from the sensor. B.) Push the green tab on the connector and disconnect the crankcase breather hose from the intake tube. Remove five bolts on the factory intake tube and remove it from the vehicle. There are four on the sides of the airbox, and one on the tube near the power steering reservoir.

2. Remove the four bolts that hold the throttlebody to the intake manifold.

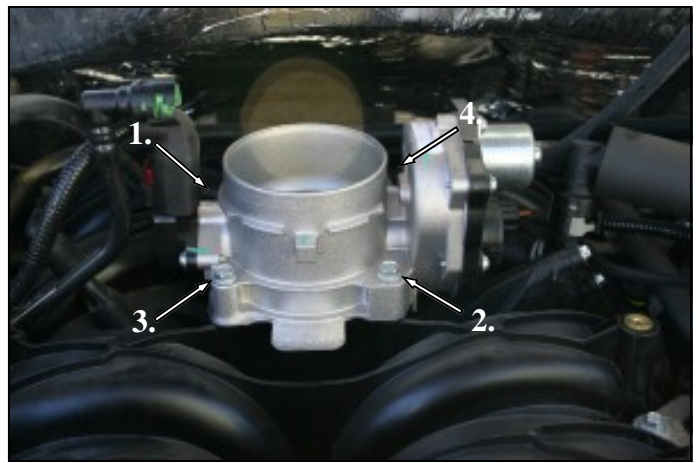
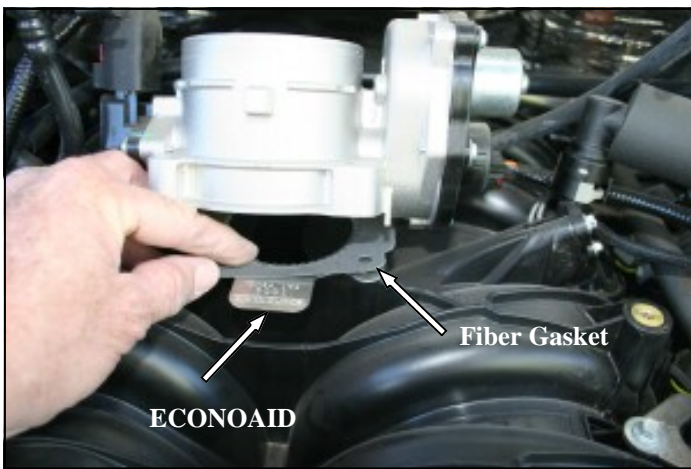

3. Install the ECONOAID Throttlebody Booster against the intake manifold with the logo facing the throttlebody. Next install the supplied gasket between the ECONOAID and the throttlebody.

4. Reinstall the factory bolts and tighten them in a cross pattern to the manufacturer's specifications. Before starting the engine, open and close the throttlebody to make sure there are no obstructions.

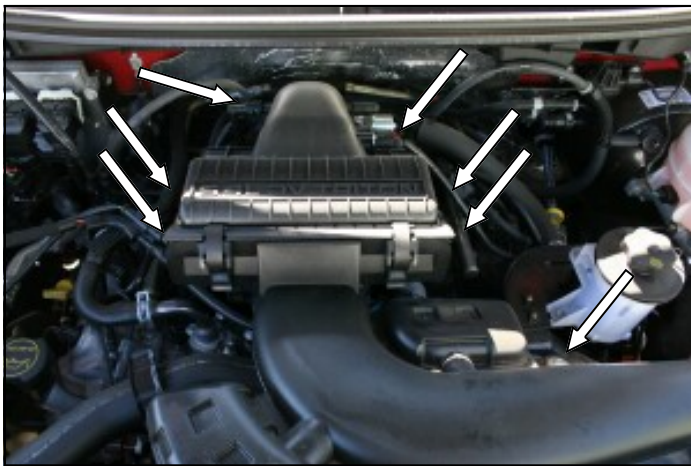

6. Double check your work. Make sure there is no foreign material in the intake tract. Make sure all clamps, hoses, connectors, nuts, and bolts are secure.

Reconnect the negative battery cable.

5. Reinstall the intake tube and tighten the five bolts. Reconnect the mass air sensor. Reconnect the crankcase breather hose.

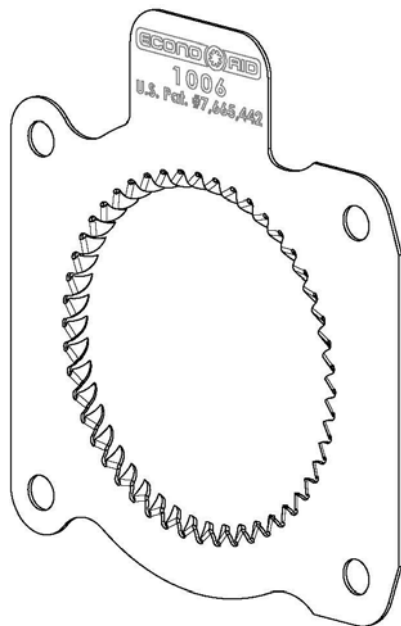

Included with your ECONOAID Throttlebody Booster is a decal with the California Air Resources Board (C.A.R.B.) Executive Order number D-520-4. This decal must be placed in plain view inside the engine compartment. Failure to do may prevent you from passing a smog inspection.

Instructions Revision
11/12/10