

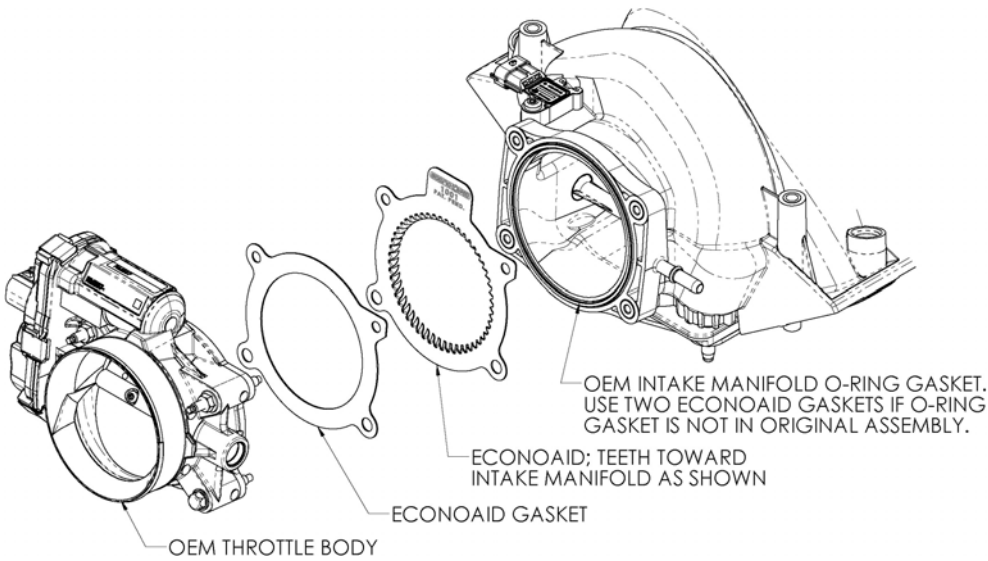

Part Number 1008

1987-95 GM C/K Pickup & SUV
5.0, 5.7L



Tools Required For Installation

5/16", 1/2" Sockets
Ratchet and Extension

Parts List

#1	ECONOAID	x1
#2	Gasket	x2

Thank you for purchasing the ECONOAID Throttlebody Booster. Please read the instruction manual carefully before proceeding with the installation. Contact ECONOAID @ (888) 876-4676 8:00 AM - 5:00 PM MST Weekdays for questions regarding fit or instructions that are not clear to you. Your ECONOAID Throttlebody Booster was carefully inspected and packaged. Check that no parts are missing, or were damaged during shipping. If any parts are missing, please contact ECONOAID.

U.S. Pat. #7,665,442



1. **Disconnect the negative battery cable!**
Remove the air cleaner assembly by removing the wing nut, disconnecting the crankcase breather hose, and the plastic fresh air tube on the passengers side.



2. Disconnect the three vacuum lines on the front of the throttle body, and disconnect the throttle cable and cruise control cables. Next remove the three bolts that secure the throttle body to the intake manifold.

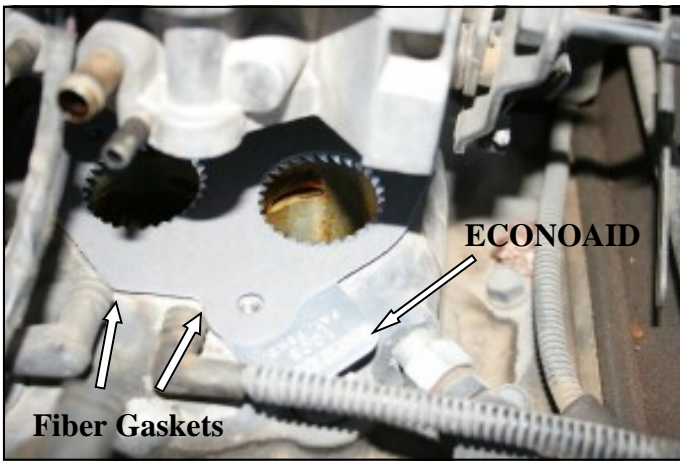

3. Carefully lift the throttlebody straight up and slide the ECONOAID Throttlebody Booster with one gasket on each side and the logo facing up, into position on top of the intake manifold. Make sure that the bolt holes in the ECONOAID and the two gaskets are aligned over the bolt holes in the intake manifold, and then reinstall the throttlebody.



4. Reinstall the factory bolts through the throttlebody and tighten them to the manufacturer's specifications. Reconnect the vacuum hoses and throttle cables. Before starting the engine, open and close the throttlebody to make sure that there are no obstructions.



5. Reinstall the air cleaner and reconnect the crankcase breather hose, and the plastic fresh air tube.

6. Double check your work. Make sure there is no foreign material in the intake tract. Make sure all clamps, hoses, nuts, cables, and bolts are secure.

Reconnect the negative battery cable.

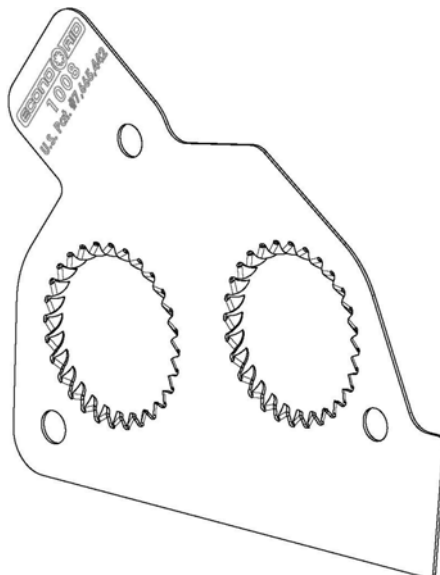

Included with your ECONOAID Throttlebody Booster is a decal with the California Air Resources Board (C.A.R.B.) Executive Order number **D-520-4**. This decal must be placed in plain view inside the engine compartment. Failure to do may prevent you from passing a smog inspection.

Instructions Revision
11/12/10