

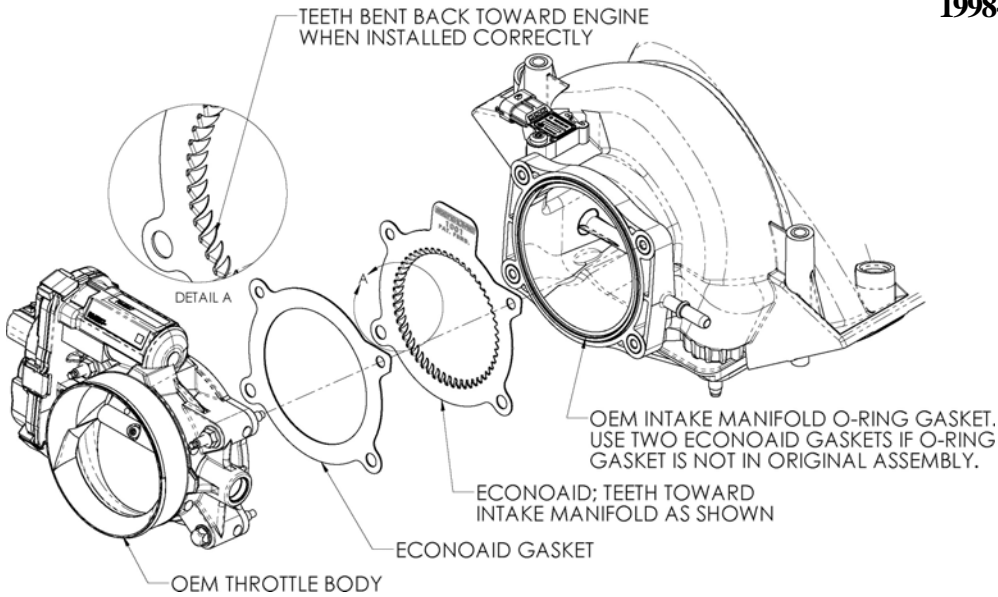

Part Number 1009

- 1996-00 Ford Crown Victoria 4.6L
- 1999-00 Ford Explorer XLT 4.0L SOHC
- 2005-09 Ford Mustang 4.0L V-6
- 1998-04 Ford Mustang GT 4.6L SOHC



Tools Required For Installation

- 5/16", 10mm Sockets
- Ratchet and Extension

Parts List

#1	ECONOAID	x1
#2	Gasket	x2

Thank you for purchasing the ECONOAID Throttlebody Booster. Please read the instruction manual carefully before proceeding with the installation. Contact ECONOAID @ (888) 876-4676 8:00 AM - 5:00 PM MST Weekdays for questions regarding fit or instructions that are not clear to you. Your ECONOAID Throttlebody Booster was carefully inspected and packaged. Check that no parts are missing, or were damaged during shipping. If any parts are missing, please contact ECONOAID.

U.S. Pat. #7,665,442



1. **Disconnect the negative battery cable!**
Remove the air intake tube between the air filter housing and the throttlebody.

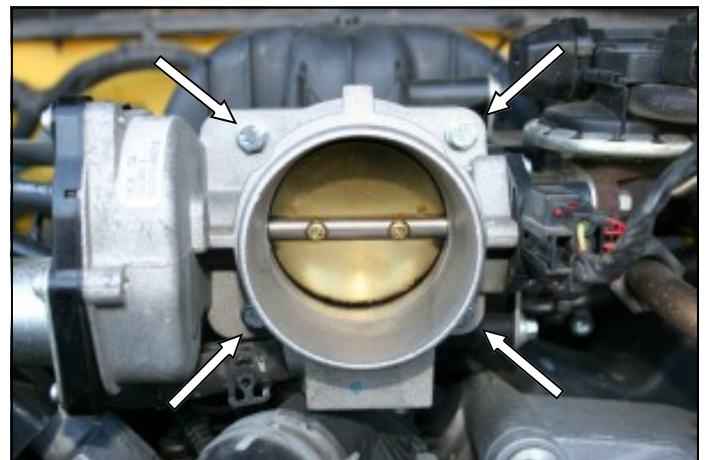

2. Remove the four bolts that hold the throttlebody onto the intake manifold.

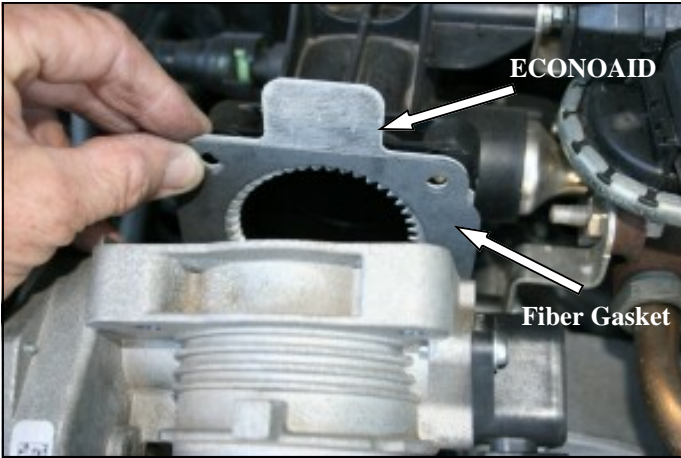

3. Install the ECONOAID Throttlebody Booster and supplied gasket between the throttlebody and the intake manifold with the logo facing the front of the vehicle. Make sure that the gasket is between the throttlebody and the ECONOAID. (If your application does not have an O-ring on the intake manifold, install the second supplied gasket between the ECONOAID and the intake manifold).

5. Reinstall the intake tube and tighten the two hose clamps. Reinstall the breather tube onto the intake tube.

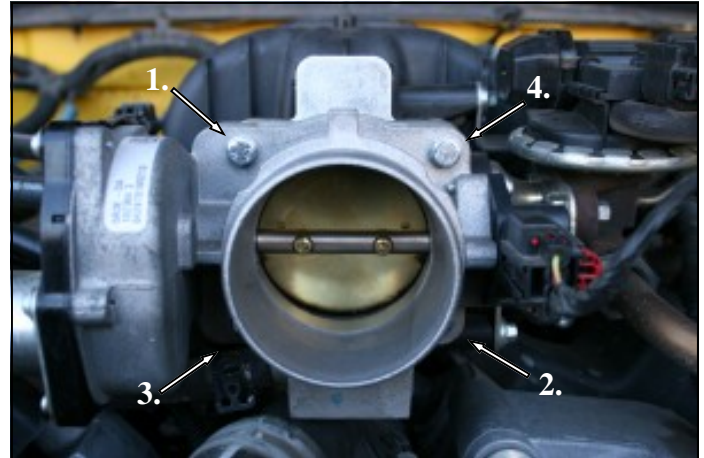

4. Reinstall the throttlebody onto the intake manifold using the factory hardware. Tighten the nuts and bolts in a cross pattern to the vehicle manufacturer's specifications. Before starting the engine, open and close the throttlebody to make sure there are no obstructions.

6. Double check your work. Make sure there is no foreign material in the intake tract. Make sure all clamps, hoses, nuts, and bolts are secure. **Reconnect the negative battery cable.**

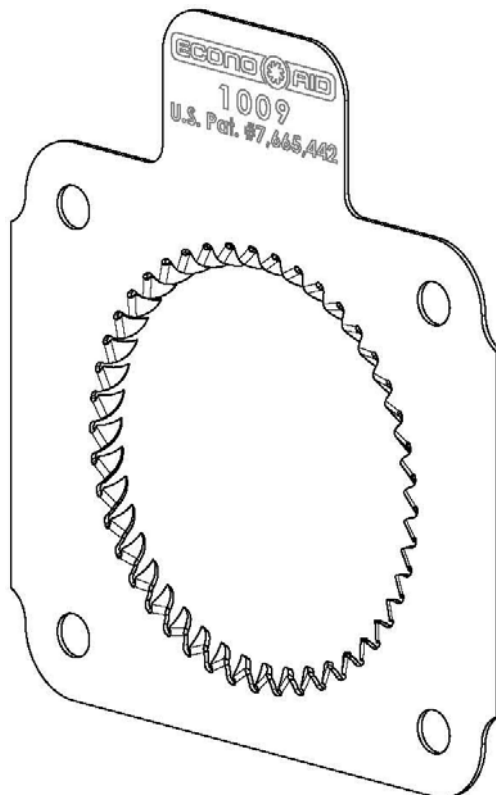

Included with your ECONOAID Throttlebody Booster is a decal with the California Air Resources Board (C.A.R.B.) Executive Order number D-520-4. This decal must be placed in plain view inside the engine compartment. Failure to do may prevent you from passing a smog inspection.

Instructions Revision
11/12/10