

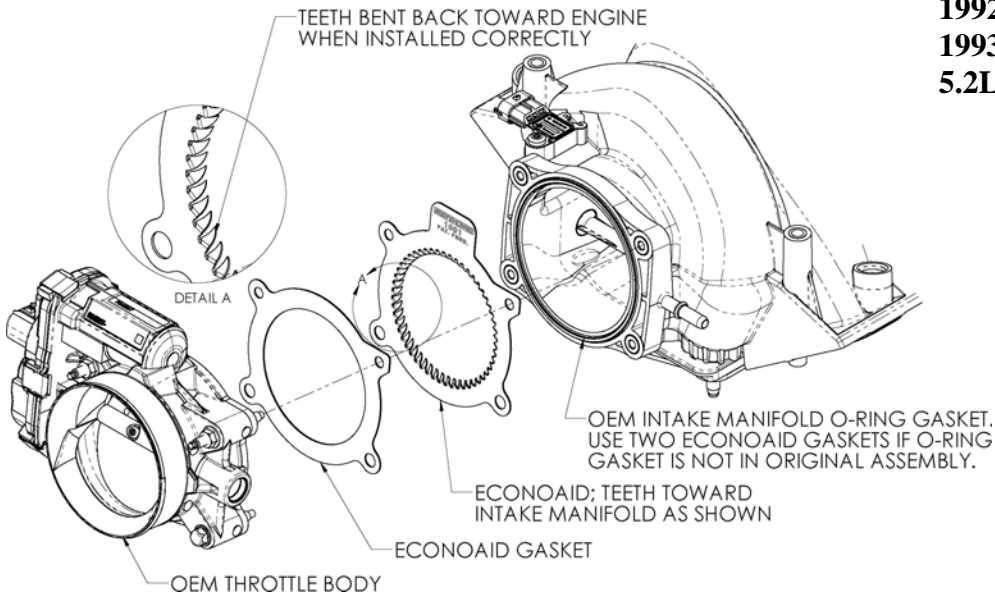

Part Number 1010

1992-03 Dodge Ram
 1992-03 Dodge Dakota
 1998-03 Dodge Durango
 1992-93 Dodge Ramcharger
 1993-98 Jeep Grand Cherokee
 5.2L, 5.9L Magnum V-8



Tools Required For Installation

5/16", 1/2" Sockets
 Ratchet and Extension

Parts List

#1	ECONOAID Plate	x1
#2	Gasket	x2



Thank you for purchasing the ECONOAID Throttle Body Plate. Please read the instruction manual carefully before proceeding with the installation. Contact ECONOAID @ (888) 876-4676 8:00 AM - 5:00 PM MST Weekdays for questions regarding fit or instructions that are not clear to you. Your ECONOAID Throttle Body Plate was carefully inspected and packaged. Check that no parts are missing, or were damaged during shipping. If any parts are missing, please contact ECONOAID.

U.S. Pat. #7,665,442



1. **Disconnect the negative battery cable!**
 Disconnect the crankcase breather hose, and the fresh air intake tube from the air filter housing.

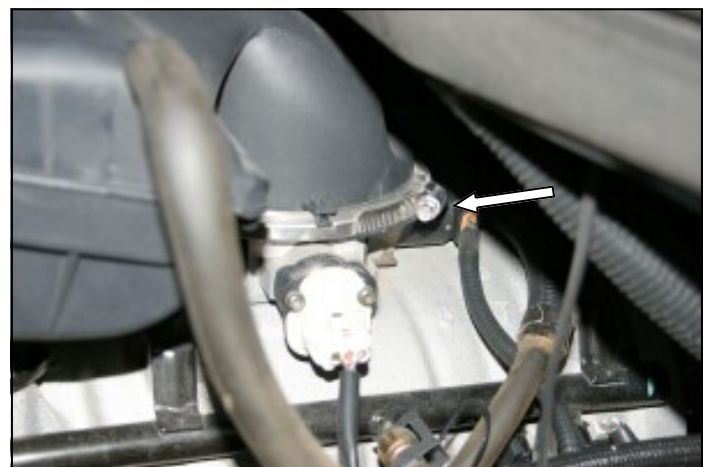

2. Loosen the band clamp that secures the air cleaner to the throttlebody. Now remove the air cleaner by lifting it straight up and out of the locating grommet.



3. Push the transmission cable end towards the front of the vehicle to unhook it from the linkage arm. Next remove the four bolts that secure the throttlebody to the intake manifold.

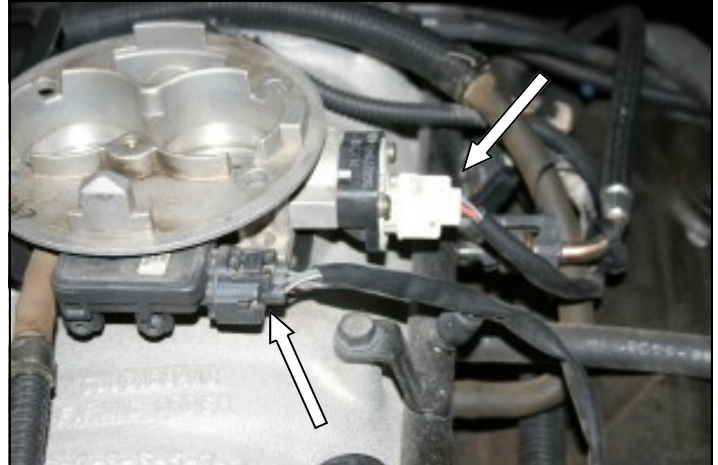

4. Disconnect the two electrical connectors on the drivers side of the throttle body.



5. Install the ECONOAID Plate against the manifold with one gasket on top of the plate, and one gasket under the plate with the ECONOAID logo facing the throttlebody.

6. Reinstall the throttlebody onto the intake manifold using the factory hardware. Tighten the nuts and bolts in a cross pattern to the vehicle manufacture's specifications. Open the throttlebody wide open by hand and make sure there are no obstructions. Reconnect the electrical connectors, and transmission cable. Reinstall the air cleaner and tighten the band clamp. Reconnect the crankcase breather hose and the fresh air tube.

7. Double check your work! Make sure there is no foreign material in the intake tract. Make sure all nuts, bolts clamps, hoses and connectors are secure.

Reconnect the negative battery cable.

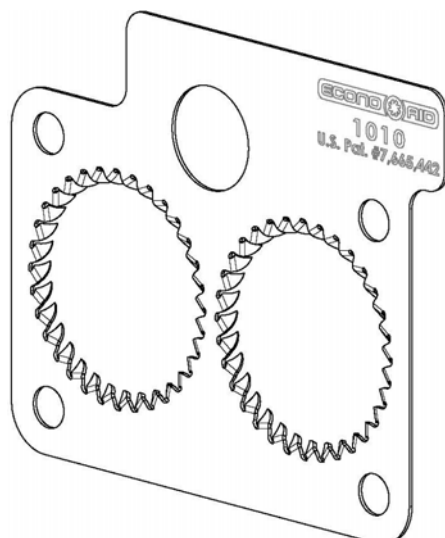

Included with your ECONOAID Throttlebody Booster is a decal with the California Air Resources Board (C.A.R.B.) Executive Order number **D-520-4**. This decal must be placed in plain view inside the engine compartment. Failure to do may prevent you from passing a smog inspection.

Instructions Revision
08/30/10