

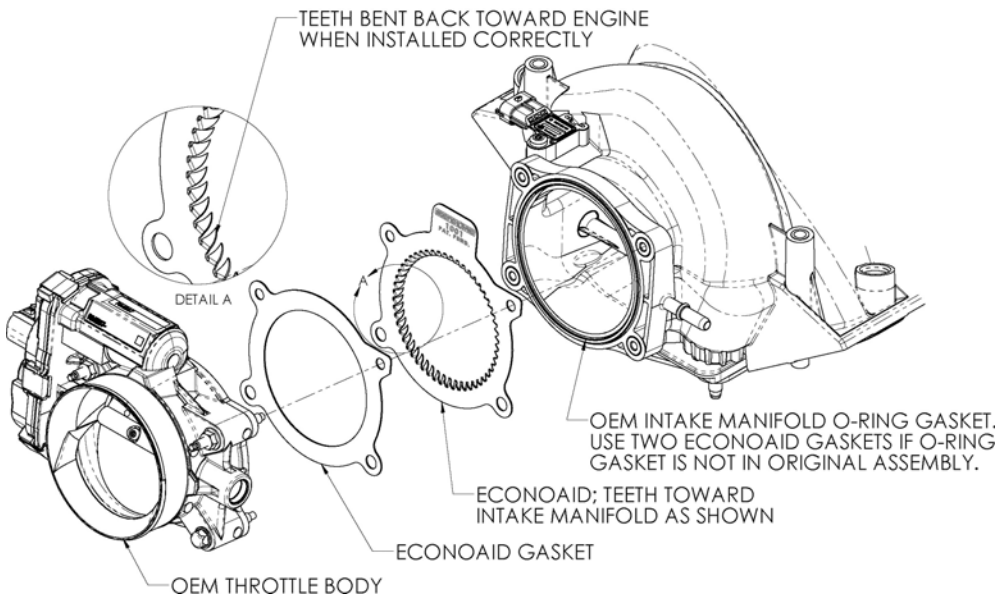

Part Number 1012
2005-09 Ford Mustang 4.6L



Tools Required For Installation

5/16", 10mm Sockets
Ratchet and Extension

Parts List

#1	ECONOAID Plate	x1
#2	Gasket	x1

Thank you for purchasing the ECONOAID Throttle Body Plate. Please read the instruction manual carefully before proceeding with the installation. Contact ECONOAID @ (888) 876-4676 8:00 AM - 5:00 PM MST Weekdays for questions regarding fit or instructions that are not clear to you. Your ECONOAID Throttle Body Plate was carefully inspected and packaged. Check that no parts are missing, or were damaged during shipping. If any parts are missing, please contact ECONOAID.

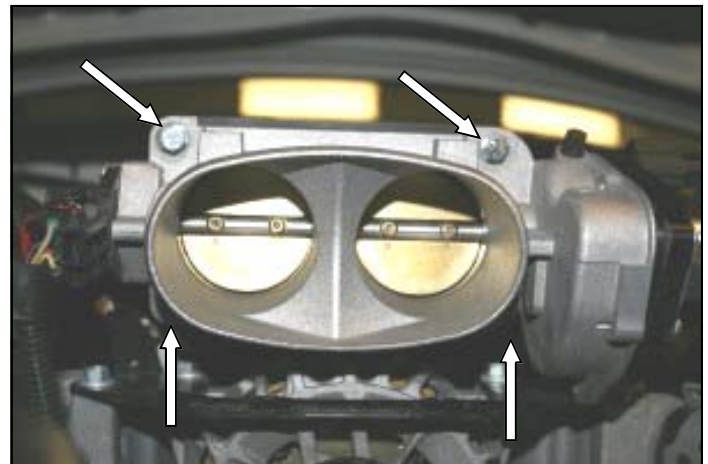

1. **Disconnect the negative battery cable!**
Push the green tab on the crankcase breather tube, and disconnect it from the air intake tube. Loosen one hose clamp on each end of the air intake tube and remove it from the vehicle.

2. Remove the four bolts that hold the throttlebody to the intake manifold.

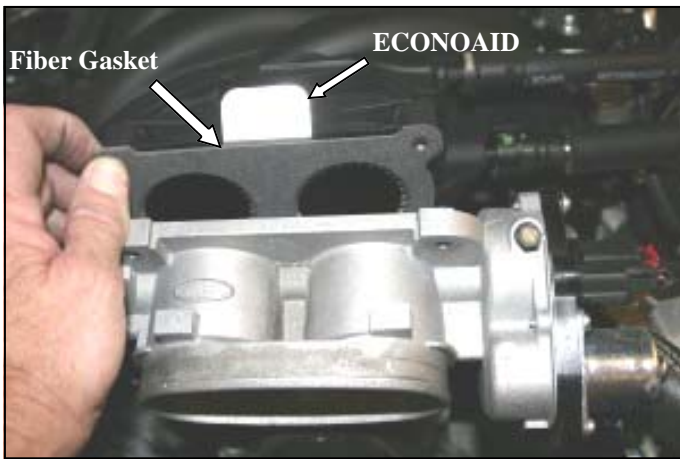

3. Install the ECONOAID Plate against the manifold with the logo facing the throttlebody. Next install the supplied gasket between the ECONOAID Plate and the throttlebody.

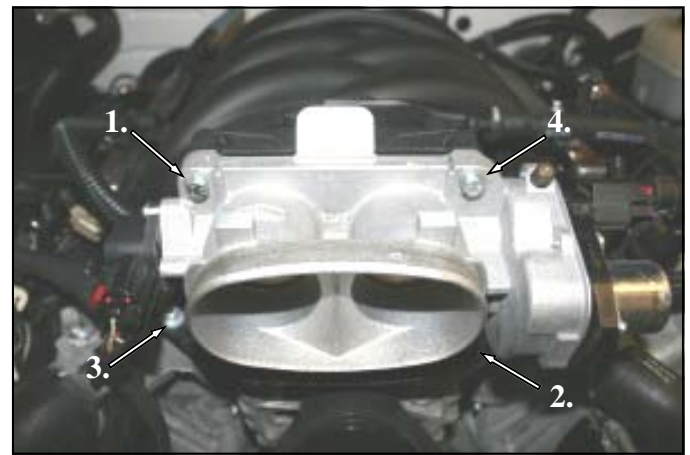

4. Reinstall the throttlebody onto the intake manifold using the factory hardware. Tighten the bolts in a cross pattern to the vehicle manufacture's specifications. Before starting the engine, open and close the throttlebody to make sure there are no obstructions.



5. Reinstall the intake tube and tighten the two hose clamps. Reconnect the crankcase breather tube onto the intake tube.

6. Double check your work. Make sure there is no foreign material in the intake tract. Make sure all clamps, hoses, nuts, and bolts are secure. **Reconnect the negative battery cable!**

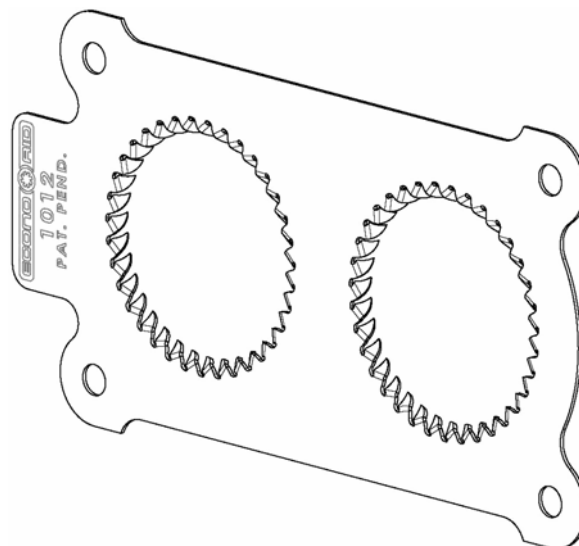

Instructions Revision
11/03/08