

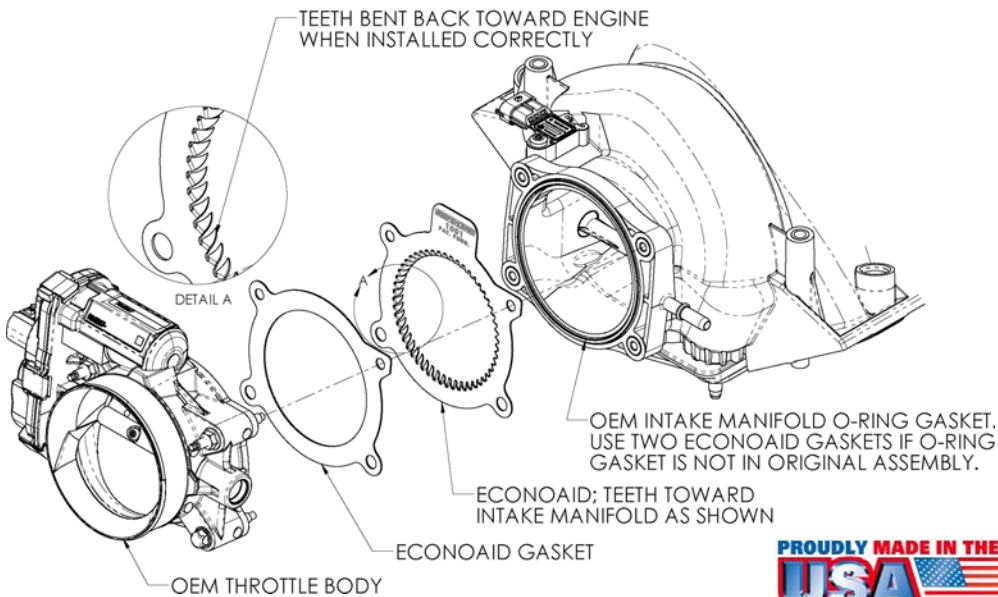

Part Number 1017

2001-09 Toyota Prius
1.5L Engine



Tools Required For Installation

10mm, 12mm Sockets
Ratchet and Extension

Parts List

#1	ECONOAID	x1
#2	Gasket	x2



Thank you for purchasing the ECONOAID Throttlebody Booster. Please read the instruction manual carefully before proceeding with the installation. Contact ECONOAID @ (888) 876-4676 8:00 AM - 5:00 PM MST Weekdays for questions regarding fit or instructions that are not clear to you. Your ECONOAID Throttlebody Booster was carefully inspected and packaged. Check that no parts are missing, or were damaged during shipping. If any parts are missing, please contact ECONOAID.

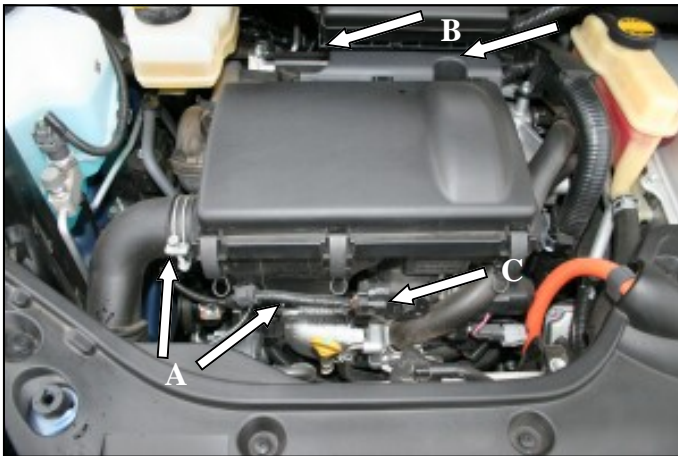

1. Disconnect the negative battery cable!

A.) Loosen the hose clamp that secures the fresh air tube to the air cleaner box. Loosen the hose clamp that secures the air cleaner box to the throttlebody. B.) Remove the two bolts that secure the air cleaner box to the engine. C.) Squeeze the tab and disconnect the Mass Air Flow sensor wiring harness from the air cleaner box. Lift the air cleaner box off of the throttlebody and set aside.

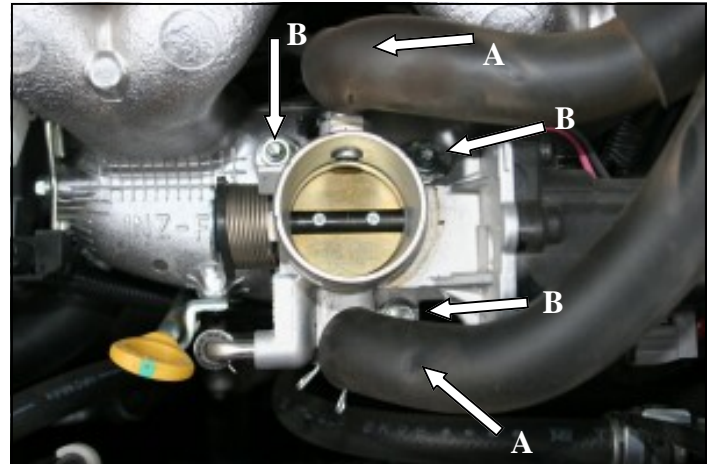

2. A.) Disconnect the two rubber hoses from the throttlebody. B.) Remove the two nuts and one bolt that secure the throttlebody to the intake manifold.

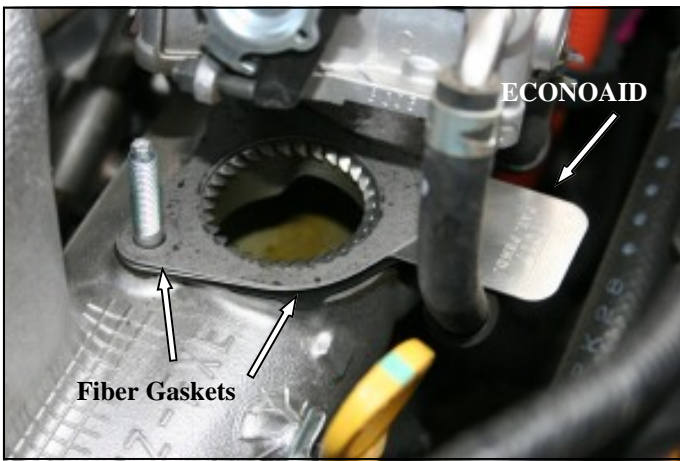

3. Lift the throttlebody off of the intake manifold and remove the old gasket. Install one supplied gasket against the intake manifold, and then the ECONOAID Throttlebody booster with the logo facing the throttlebody. Next install the remaining gasket between the ECONOAID and the throttlebody.

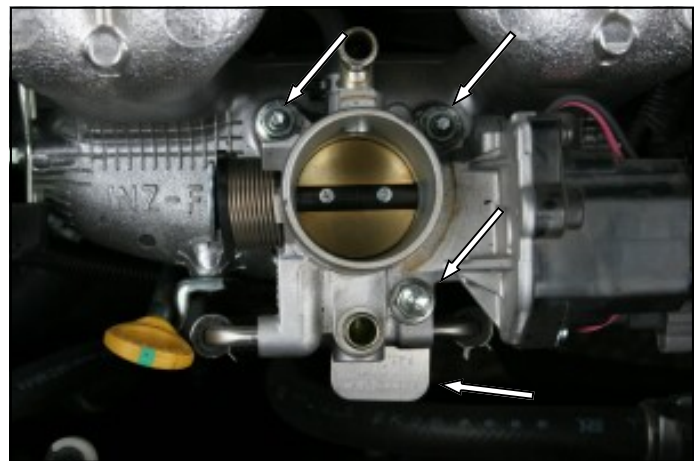

4. Reinstall the throttlebody onto the intake manifold and tighten the two nuts and one bolt to the vehicle manufacturer's specifications. Before starting the engine, open and close the throttlebody to make sure there are no obstructions. Reconnect the two rubber hoses to the throttlebody.



5. Reinstall the air cleaner box onto the top of the throttlebody. Reconnect the fresh air tube and tighten the clamp. Tighten the clamp on the throttlebody. Reinstall the two bolts that secure the airbox to the engine. Reconnect the Mass Air sensor wiring harness.

7. Double check your work. Make sure there is no foreign material in the intake tract. Make sure all clamps, hoses, nuts, bolts and connectors are secure.

Reconnect the negative battery cable.

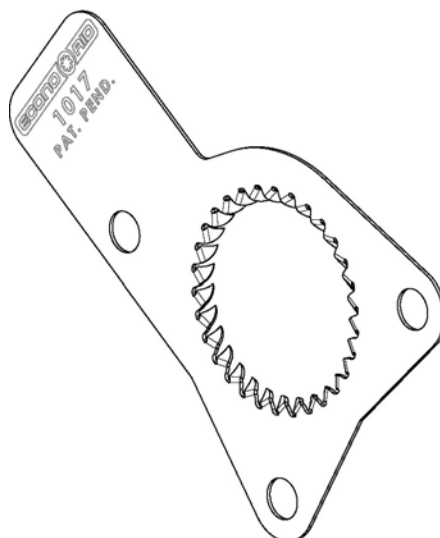

Instructions Revision
11/26/08