

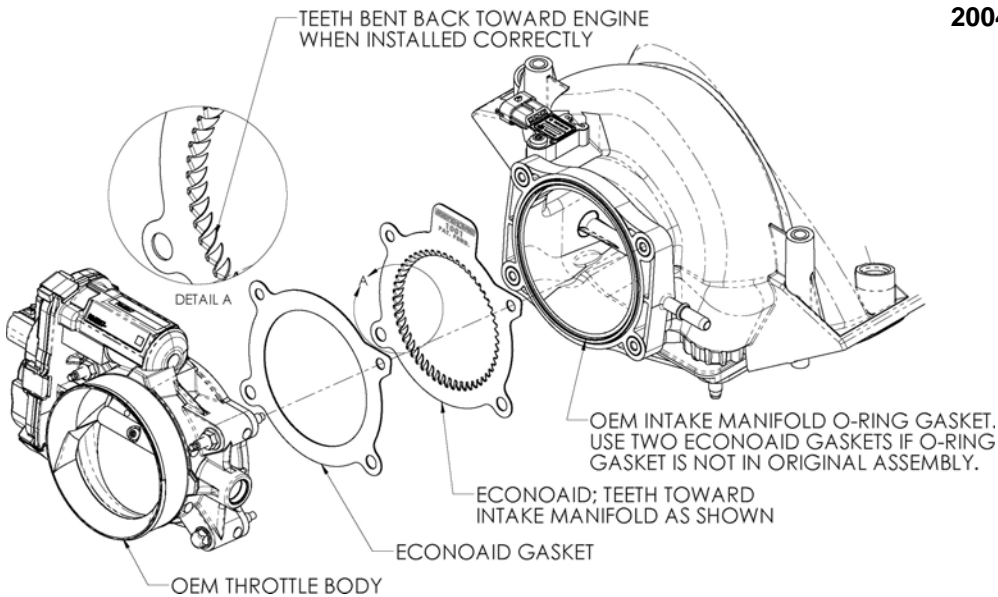

Part Number 1020

2002-06 Nissan Altima 2.5L
2002-06 Nissan Sentra 2.5L SE-R & SE-R
SPEC V
2003 Nissan Sentra 2.5LE
2004 Nissan Sentra 2.5S



Tools Required For Installation

5/16", 10mm Sockets
Ratchet and Extension
5mm Allen Wrench
Pliers

Parts List

| | | |
|----|----------|----|
| #1 | ECONOAID | x1 |
| #2 | Gasket | x2 |

Thank you for purchasing the ECONOAID Throttlebody Booster. Please read the instruction manual carefully before proceeding with the installation. Contact ECONOAID @ (888) 876-4676 8:00 AM - 5:00 PM MST Weekdays for questions regarding fit or instructions that are not clear to you. Your ECONOAID Throttlebody Booster was carefully inspected and packaged. Check that no parts are missing, or were damaged during shipping. If any parts are missing, please contact ECONOAID.

U.S. Pat. #7,665,442



1. **Disconnect the negative battery cable!**
Using a 5mm Allen wrench remove the 4 Allen bolts that secure the beauty cover to the engine. Remove the cover and set it aside.



2. A.) Loosen the two hose clamps that secure the air intake tube between the air cleaner box and the throttlebody. B.) Using pliers, squeeze the hose clamp that secures the crankcase breather hose to the valve cover and slide it up the breather hose so it won't get lost. Remove the intake tube assembly and set it aside.

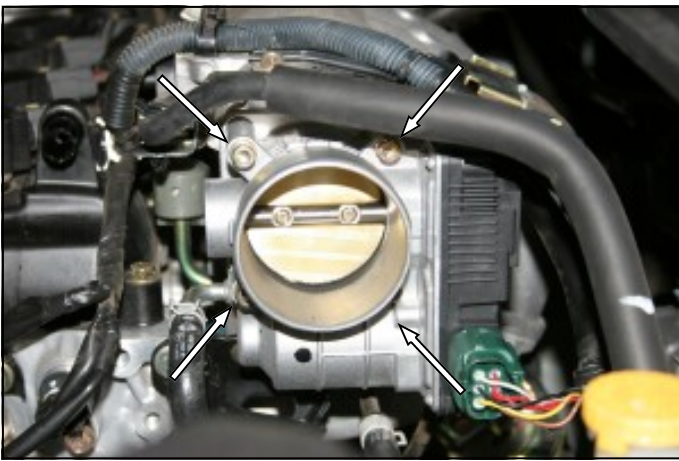

3. Remove the 4 bolts that secure the throttlebody to the intake manifold. Remove the throttlebody from the intake manifold and remove the old gasket.



4. Install one of the supplied gaskets on each side of the ECONOAID Throttlebody Booster and then install the ECONOAID between the intake manifold and the throttlebody making sure that the logo is facing the throttlebody.

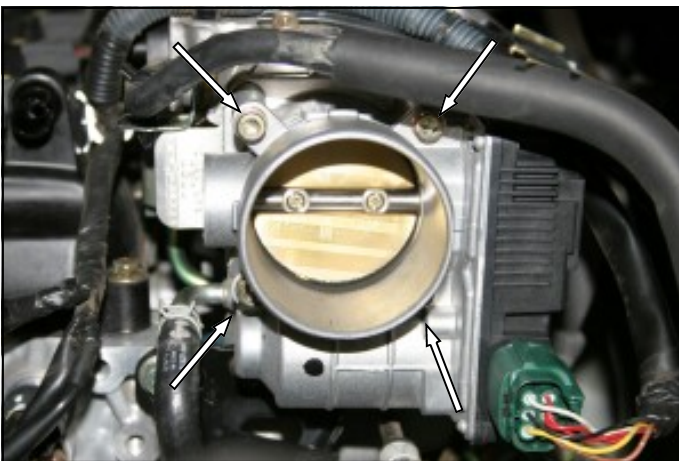

5. Reinstall the throttlebody onto the intake manifold and tighten all four bolts to the vehicle manufacturer's specifications. Before starting the engine, open and close the throttlebody to make sure there are no obstructions. Reinstall the intake tube and the beauty cover in the reverse order that they were removed.

6. Double check your work. Make sure there is no foreign material in the intake tract. Make sure all clamps, connectors, hoses, nuts, and bolts are secure.

Reconnect the negative battery cable.

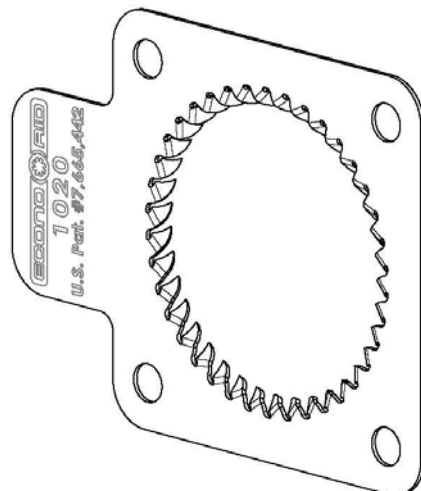

Included with your ECONOAID Throttlebody Booster is a decal with the California Air Resources Board (C.A.R.B.) Executive Order number D-520-4. This decal must be placed in plain view inside the engine compartment. Failure to do may prevent you from passing a smog inspection.

Instructions Revision
11/12/10